

305: Bench Unit Instructions

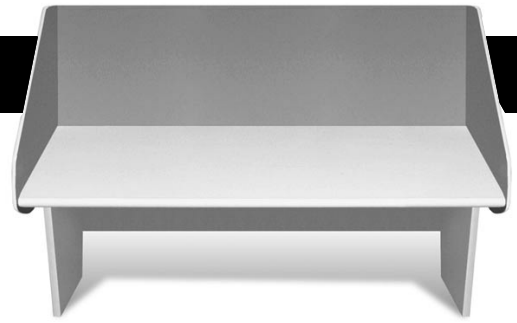

Hardware List:

Qty.	Item
2	Oval Gronnets
20	#8 Screws (1½")
8	¼" - 20 x 2¼" Carriage Bolt
6	¼" - 20 x 3½" Carriage Bolt
4	¼" - 20 Acorn Nuts
10	¼" - 20 Hex Nut
14	¼" - Washer

Thank you for purchasing your DEPCO Technology Lab Furniture! If you need further assistance, please call 1-800-767-1062.

Step 1:

Stand back panel and side panels upright and attach together by locking 6 white assembly fittings. After locking together, lay back flat on floor.

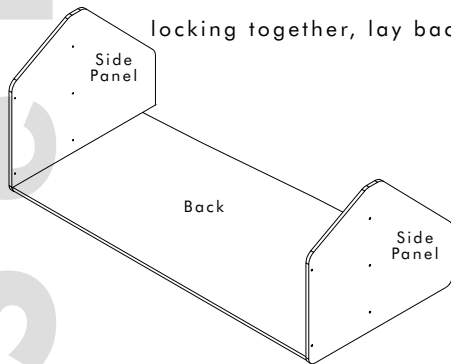

Step 2:

Attach legs to side panels with (4) - 2¼" carriage head bolts, place acorn nuts and washers on. DO NOT fully tighten nuts to allow for some play for assembly purposes.

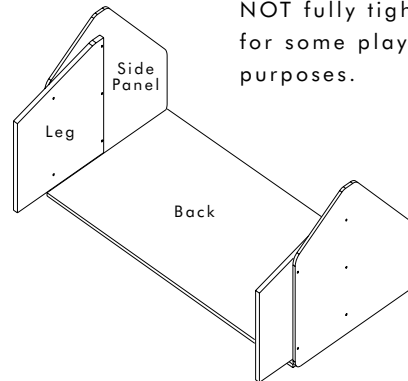

Note: Leave the top three holes on each leg open they will be used later.

Step 3:

While flat on the floor attach the metal frame (welds down) to the sides and legs of the assembly with (6) 3½" carriage head bolts and secure with nuts and washers. Stand upright and secure back to frame using (4) 2¼" carriage head bolts with washers and nuts.

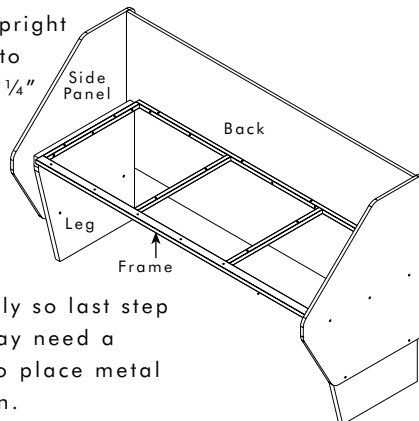

Note: DO NOT tighten completely so last step is easier. You may need a second person to place metal frame in position.

Step 4:

Place top on and fasten with 1½" wood screws.

Note: Now you should tighten all bolts and nuts.

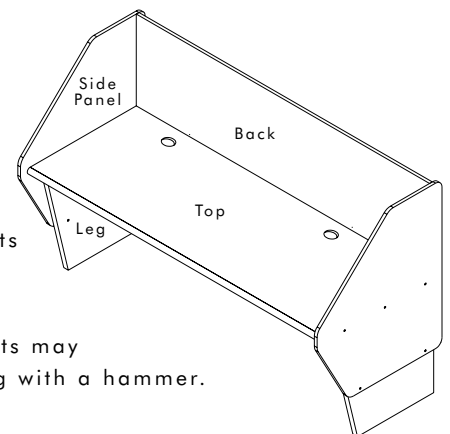

Insert Grommets in pre-drilled holes.

Note: Grommets may require tapping with a hammer.

