

801: Video Workstation

Hardware List:

Qty.	Item
20	#8 Sht Mr Screws (5/8")
28	3/4" - Black Screws
5	#6 Black Flat Head Screws (3/4")
1	Powerstrip
2	Wire Channels
4	Castors (2 Lockable - 2 Unlockable)



Step 1:

Attach small angle iron. (One to each leg.)

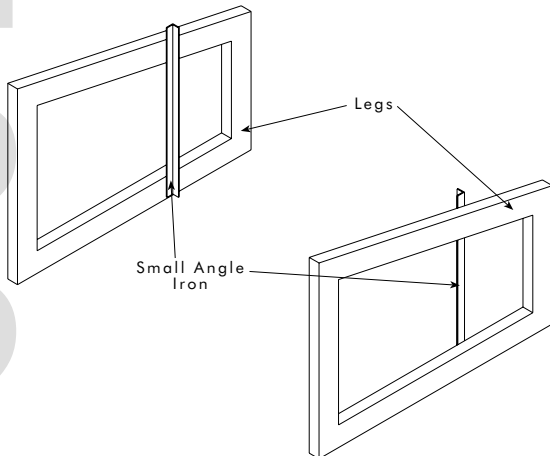

Step 2:

Attach lower side bracings.

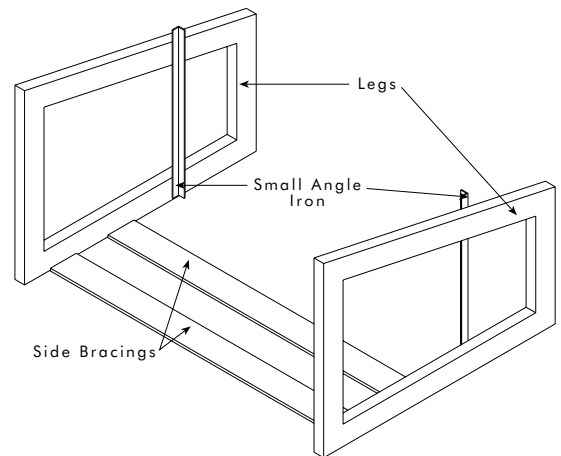

Step 3:

Attach top bracing.

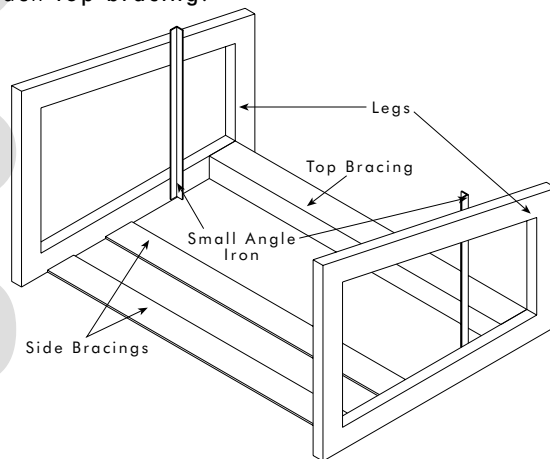

Step 4:

Attach bottom bracing to the sides. Front brace should have a chrome sleeve on it.

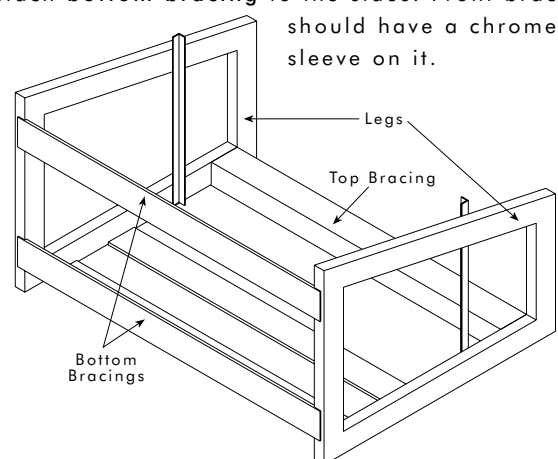

801: Video Workstation

Step 5:

Attach casters, screwing them all the way in.

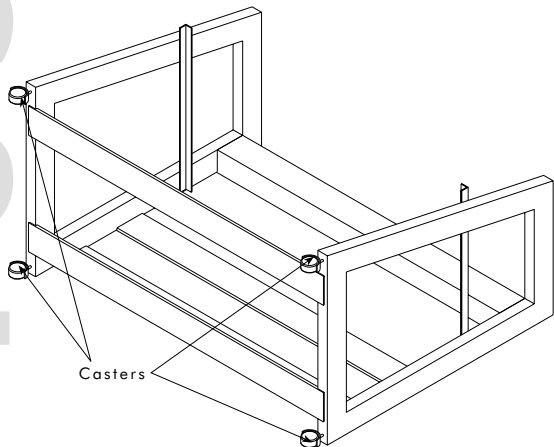

Step 6:

Rotate to its upright position and attach the angle iron bracing.

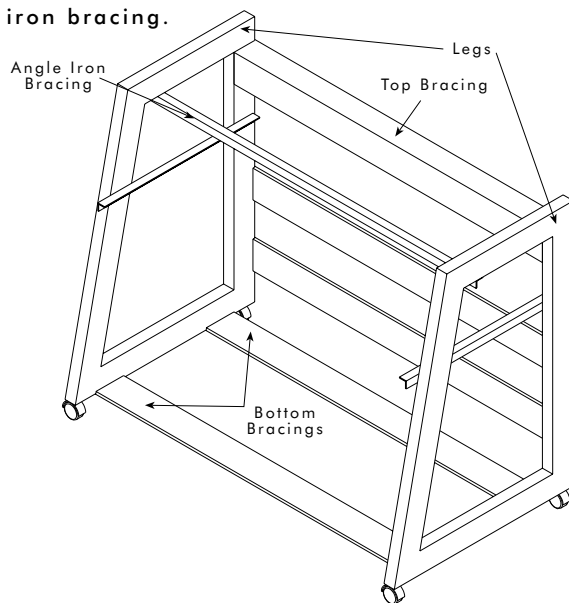

Step 7:

Attach the upper work surface with #8 screws.

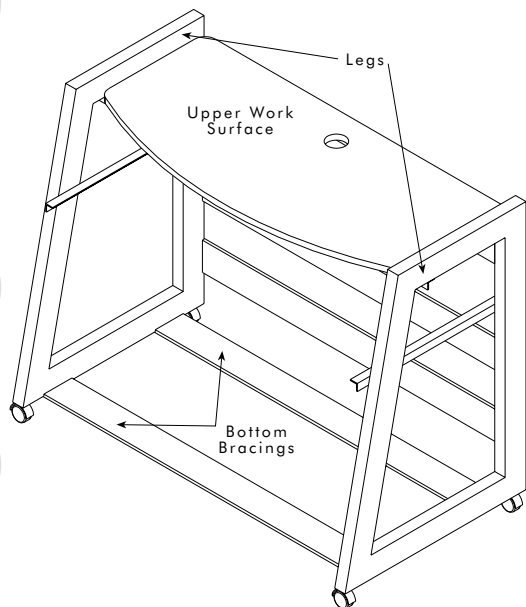

Step 8:

Attach the lower work surface with #8 screws.

Note: After attaching lower work surface, tighten all the hardware.

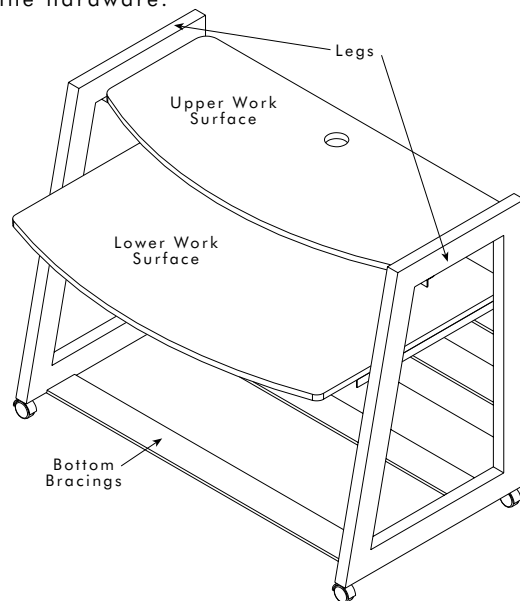

801: Video Workstation

Step 9:

Attach the **backing**. Make sure that the backing is flush with the **top bracing**. Pre-drill the frame using holes in back and attach using #6 screws.

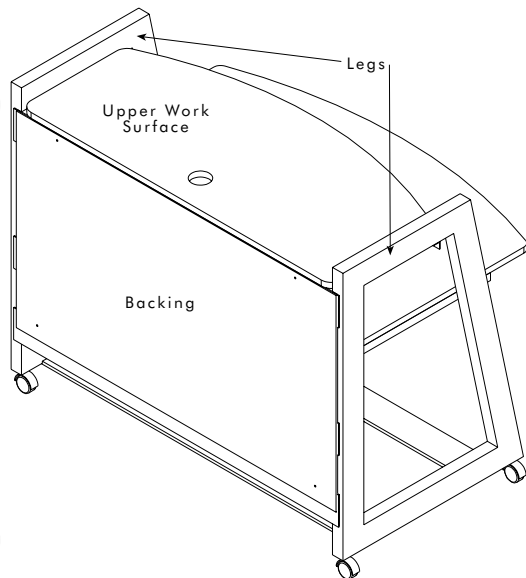

800 Series



PO Box 176 | 3305 Airport Dr. | Pittsburg, KS 66762 | 1-800-767-1062 | Fax: 316-231-0019 | sales@depcoinc.com

1 - 8 0 0 - 7 6 7 - 1 0 6 2 • w w w . d e p c o i n c . c o m